

Waterproof Junction Box - INSX120

Material: Aluminum

Dimensions: 115mm x 160mm x 35mm **Color:** White

Type of Installation: Wall

Net Weight: 0.5kg

Load Bearing Capacity: 10kg

Compatible with : INSX300S or INSX100 or INSX303

or INSX150 or INSX152



Applications

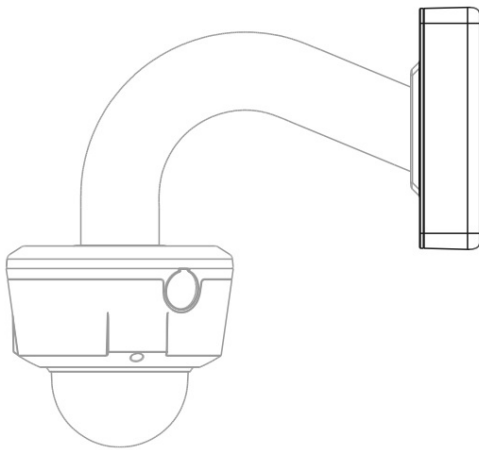

Dimensions (mm)

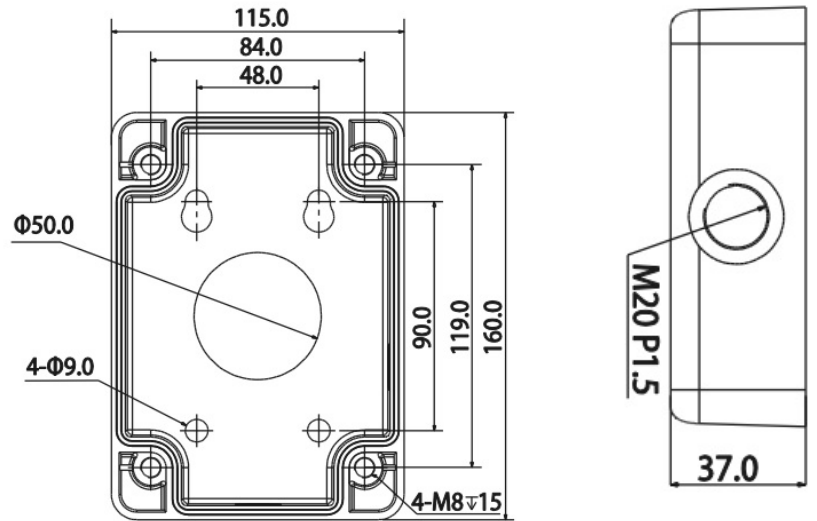

Works with



INSX300S



INSX100



INSX303



INSX150



INSX152